

8 7 6 5 4 3 2 1

E

D

C

B

DO NOT SCALE DRAWING

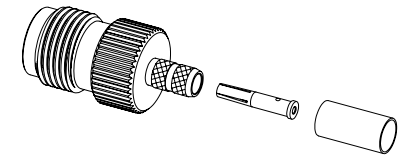
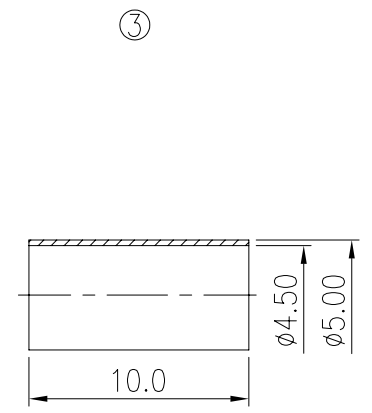
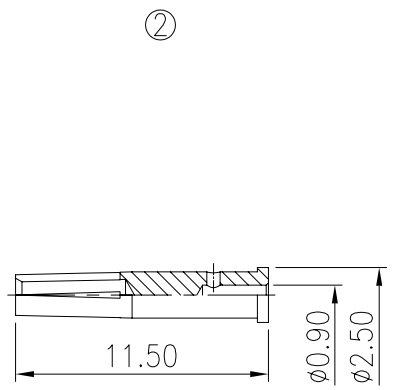
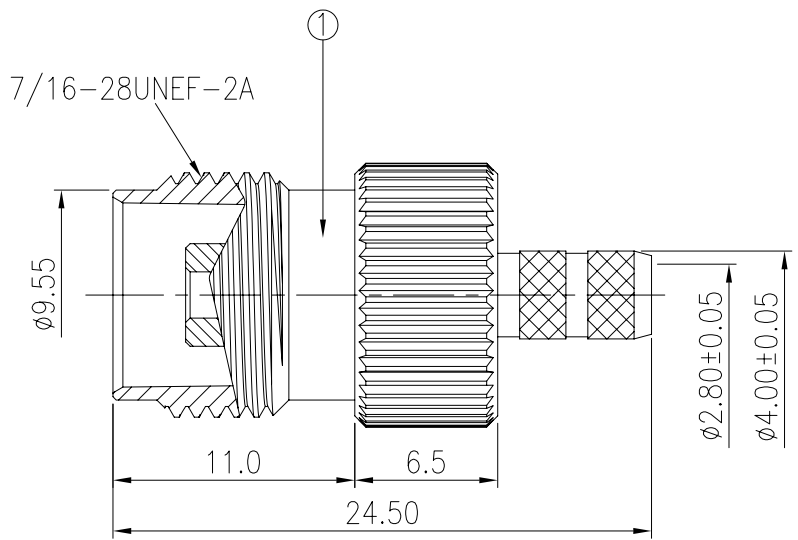

SCALE 1:1

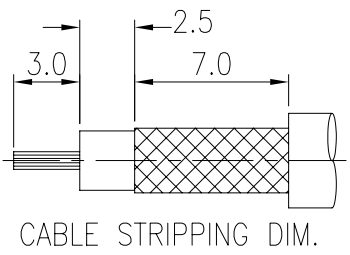

3	1	INSULATOR	21-109E0-02NA	BRASS	NICKEL PLATED
2	1	CONTACT	12-130E0-02GD	PHOSPHORUS BRONZE	GOLD PLATED
1	1	WASHER	S12-130E0	STEEL	NICKEL PLATED
	1	INSULATOR		TEFLON	NONE
	1	BODY		BRASS	NICKEL PLATED
NO.	QTY	DESCRIPTION	PART'S NO.	MATERIAL	FINISH

GENERAL TOLERANCES
 DIM: .X±0.25(0.01) .XX±0.12(0.005)
 ANGULAR: ±3°

DIMENSION CLASSIFICATION
 ■: CRITICAL ☒: MAJOR



MATERIAL : SEE TABLE
 FINISH : SEE TABLE

DRAWN BY: EUGENE 7/16/2007
 CHK'D BY:
 APP'D BY :
 SCALE : 3 : 1

ALINER 圓陵工業股份有限公司
 ALINER INDUSTRIES, INC.

TITLE: TNC CRIMP ST. JACK FOR 2.5D-2V CABLE

LTR REVISION RECORD ECN DR/CHK DATE REVISE ONLY ON CAD SYSTEM SHEET 1 OF 1 UNIT : mm DWG. NO.: 12-130E0-B REV A

8 7 6 5 4 3 2 12-130E