

8 7 6 5 4 3 2 1

E
D
C
B
A
DO NOT SCALE DRAWING

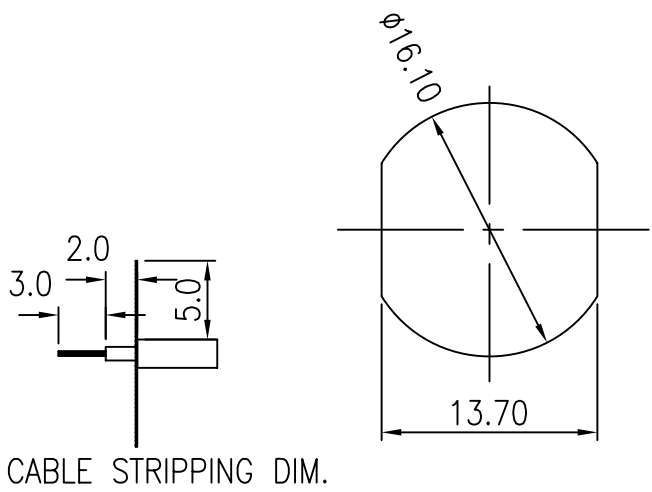
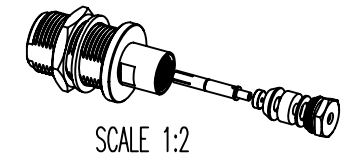
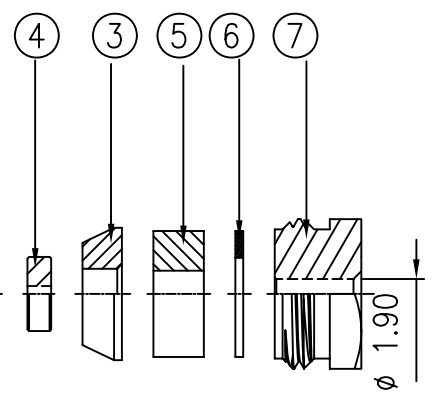
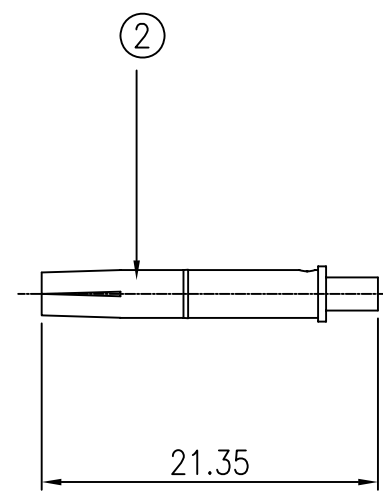
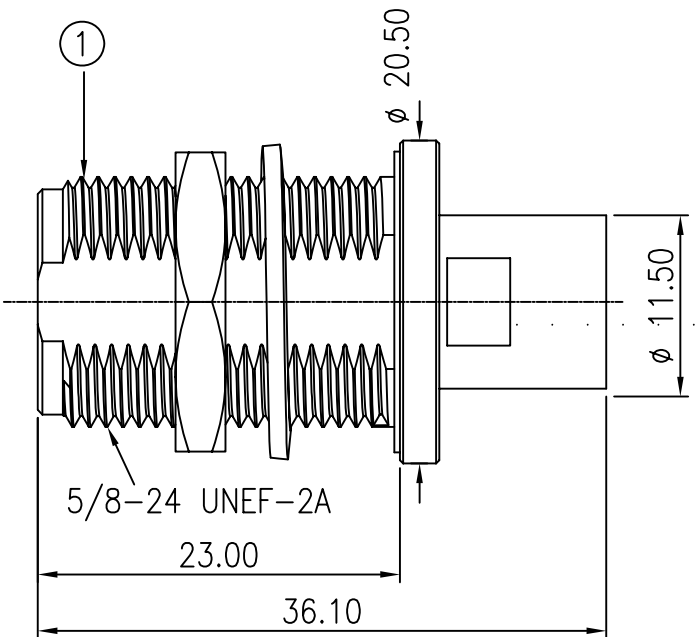
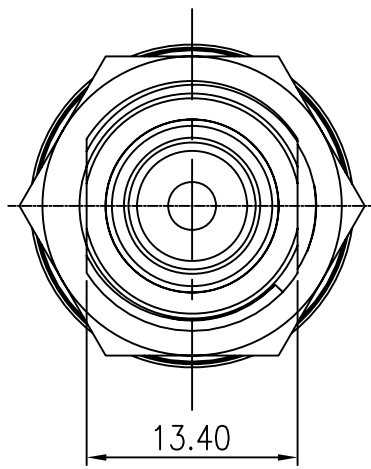

NO.	QT'Y	DESCRIPTION	PART'S NO.	MATERIAL	FINISH
7	1	NUT	18-104AB-03NA	BRASS	NICKEL PLATED
6	1	WASHER	18-101B0-06NA	STEEL	NICKEL PLATED
5	1	GASKET	18-101B0-0700	SILICON RUBBER	NONE
4	1	INSULATOR	18-104A0-0400	TEFLON	NONE
3	1	CLAMP	18-101B0-04NA	BRASS	NICKEL PLATED
2	1	CONTACT	18-104AB-02GE	BRASS	GOLD PLATED
1	1	SLEEVE	S18-104AB	BRASS	NICKEL PLATED
	1	WASHER		STEEL	NICKEL PLATED
	1	NUT		BRASS	NICKEL PLATED
	1	INSULATOR		TEFLON	NONE
	1	GASKET		SILICON RUBBER	NONE
	1	BODY		BRASS	NICKEL PLATED
NO.	QT'Y	DESCRIPTION	PART'S NO.	MATERIAL	FINISH

GENERAL TOLERANCES
 DIM: .X±0.25(0.01) .XX±0.12(0.005)
 ANGULAR: ±3°

DIMENSION CLASSIFICATION
 ■: CRITICAL ☒: MAJOR

MATERIAL : SEE TABLE
 FINISH : SEE TABLE
 DRAWN BY: YVONNE 3/12/2007
 APP'D BY: _____
 SCALE : 2 : 1

ALINER 圓陵工業股份有限公司
 ALINER INDUSTRIES, INC.
 TITLE: TYPE N BULKHEAD CLAMP FOR RG-178 CABLE

LTR REVISION RECORD ECN DR/CHK DATE REVISE ONLY ON CAD SYSTEM SHEET 1 OF 1 UNIT : mm DWG. NO.: 18-104AB-B REV A

8 7 6 5 4 3 2 1